



CITY OF STE. GENEVIEVE, MISSOURI

165 S. Fourth Street
Ste. Genevieve, MO 63670
Phone (573) 883-5400 Fax (573) 883-8105

Chicken Permit Application

Ordinance # 4037

Annual Fee: \$10.00 Payment Date Paid: _____ Paid by: _____
Property Owner's Name: _____ Phone: _____
Address: _____ Email: _____
Zone of Property: _____ Number of Hens Requested (6 max): _____

Please complete and submit the following:

1. Site plan and survey clearly depicting the location of the coop and outdoor pen (see sample attached). The distances between the coop and outdoor pen and side and rear property lines MUST be dimensioned (see sample attached).
2. Pictures or specifications of coop and of outdoor pen. Pictures or specifications MUST be dimensioned with width x length x height.
3. Annual application fee \$10.
4. Initial and sign below acknowledging that you are aware of the applicable regulations to keeping chickens and you agree to adhere to the regulations at all times.

_____ **The keeping of chickens shall be allowed on all detached single family lots under the following conditions.**

_____ **Permits and Fees:**

- A. Upon application submitted with a \$10.00 application fee per household, the City may issue a one-year permit if, after inspection, it is shown that location and facilities provided comply with all regulations as set out in this Article.
- B. Annual renewal application, \$10.00 fee and inspection.

_____ **Number of chickens allowed:**

- A. No more than six (6) hens shall be allowed for each single-family dwelling. None shall be allowed in multi-family complexes, including condos and duplexes.
- B. No roosters shall be allowed.

_____ **Enclosure/containment requirements:**

- A. Not permitted to "run at large".
- B. May not be kept inside the habitable areas of the dwelling.
- C. A coop must be provided with minimum square footage of three (3) square ft. per bird. Design and construction of coop is to be reviewed and approved by City staff.
- D. Coop may be kept inside the garage (finished or unfinished), unfinished or non-habitable areas in basement or cellars and non-habitable accessory structures.
- E. Outdoor pen/run must be provided; minimum square footage per bird is ten (10) square ft.
- F. Pen/run may not be located indoors (i.e. garage, basement, cellar or accessory structure). It may not be located in the front or side yards.
- G. An outdoor coop and/or pen used exclusively for chickens will not count towards the maximum number of accessory structures allowed on a parcel.
- H. Coop and outdoor pen/run must be kept in a neat and sanitary condition at all times. They must be cleaned regularly so as to prevent offensive odors, insects and disease.

_____ **Distance regulations:**

- A. Outdoor pen/run and coop must be situated a minimum of ten (10) ft. from the property line.
- B. Notification of neighbors is part of the permit process, but support letters are not needed.
- C. Pen and coop designs, materials and screening shall be subject to Staff approval for design, materials and location.

CITY OF STE. GENEVIEVE, MISSOURI

165 S. Fourth Street
Ste. Genevieve, MO 63670
Phone (573) 883-5400 Fax (573) 883-8105

Chicken Permit Application

Ordinance # 4037

Nuisances:

Noises and Noxious Odors: It shall be unlawful for any person owning chickens to give forth or cause any loud or unusual noise or to cause any ill-smelling, nauseous or obnoxious odors. If such person owning chickens causing or creating any such noise or odor shall cure, remedy and entirely alleviate the odor or noise within ten (10) days after the service of a notice to do so upon him/her by any member of the Police Department, no punishment shall be assessed or imposed against that person. If the odor or noise is not cured, remedied and entirely alleviated within ten (10) days after service of the notice, the person served shall be deemed guilty of a misdemeanor.

Nuisances:

1. The accumulation upon any premises, lot or parcel of ground or the discharge thereof, upon any public street or private property, of stagnant or foul waste, water or liquids of any kind whatsoever;
2. The keeping of chickens, upon any public or private place or premises in such a manner or condition that constitutes a hurt, injury, annoyance or danger to the public or the residents of the vicinity;
3. Placing, causing, keeping, maintaining or permitting trash, garbage, rubbish, junk, decaying vegetable or animal matter, ashes, debris, noxious or filthy substances or any kind of waste materials upon any public or private property or premises in such manner and to such extent as to render the same unsightly, unclean or unsafe;

Slaughtering restrictions:

Any slaughtering of chickens shall not be visible on premises.

Miscellaneous regulations:

- A. May not breed chickens for sale or sell any of their bi-products.
- B. Chicken feed must be stored in rat-proof containers.
- C. Chickens currently kept shall not be "grandfathered" or permitted to remain after the effective date of this ordinance unless brought into compliance.

Neighbor Notification:

Neighbors' signatures below indicate acknowledgement of notification of neighbor's intent to keep up to six (6) chickens on their property located at: _____ per City
(Ordinance # 4037) regulations itemized above.

Neighbor's Name and Address

Neighbor's Signature

_____	_____
_____	_____
_____	_____

Applicant's Signature

Application Date

(For Staff Use Only)

Inspection Date: _____ Inspector: _____ Pass/Fail: _____

Permit #: _____ Permit Expiration Date: _____

City Staff Member's Signature of Approval

Date of Approval

CITY OF STE. GENEVIEVE, MISSOURI

165 S. Fourth Street
Ste. Genevieve, MO 63670
Phone (573) 883-5400 Fax (573) 883-8105

Chicken Permit Application

Ordinance # 4037

SAMPLE COOP & PEN WITH DIMENSIONS

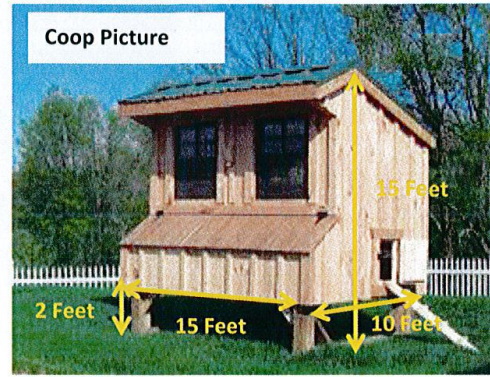
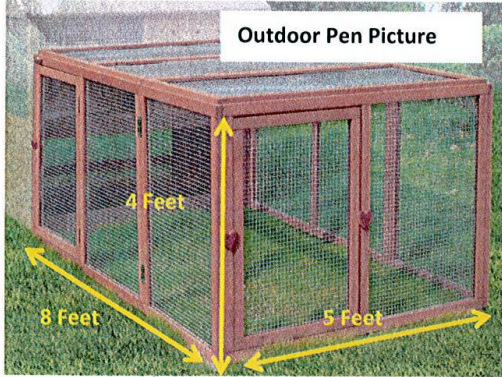

Combined Outdoor Pen & Coop Picture

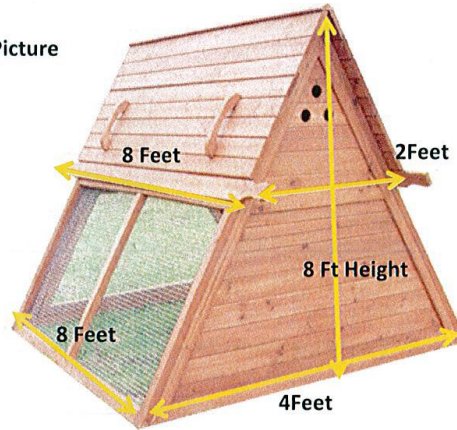

Combined Outdoor Pen & Coop Specification

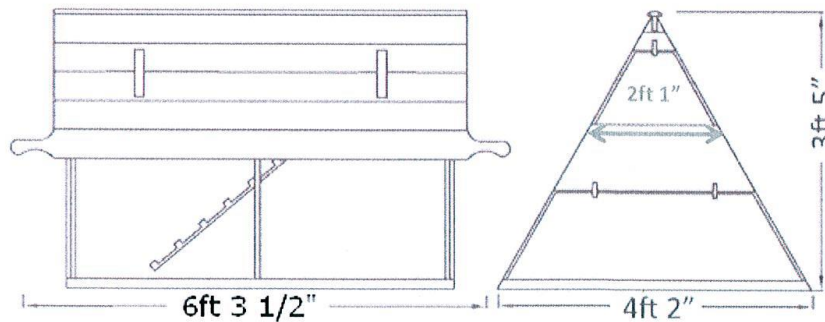

CITY OF STE. GENEVIEVE, MISSOURI

165 S. Fourth Street
 Ste. Genevieve, MO 63670
 Phone (573) 883-5400 Fax (573) 883-8105

Chicken Permit Application

Ordinance # 4037

